

GT-4 PRO

SETUP SHEET

DATE: 12/18/01
 NAME: Team Yokomo
 TRACK: Standard Setup
 FASTEST LAP: _____

Front Suspension

Plastic [Shock body type] Alum

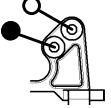
Length 63.0 mm
 Preload See comments mm
 Spring Grey (#YS-1755)
 Shock oil #450
 Piston #2 (Yok)
 Shock position 

Caster [Shims behind upper arm]
 Thick (2.6mm) 2
 Thin (1.3mm) 1

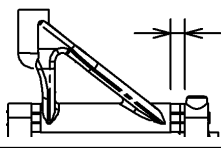
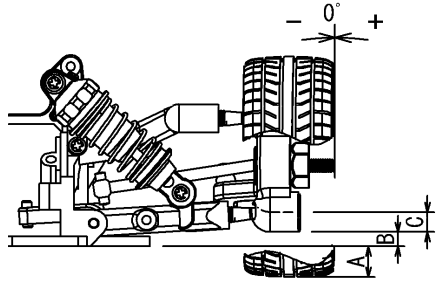



Width 200 mm
 Camber -2.0 °
 Ride height 4.0 mm
 Downstop 1.0 mm
 Bumpstop 3.0 mm
 Toe angle +1.0 °

Front anti-roll bar None 20 °
 Front one-way differential Gear diff Diff grease KIT

Rear Suspension

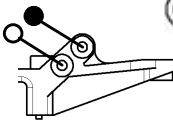
Plastic [Shock body type] Alum

Length 63.0 mm
 Preload See comments mm
 Spring Grey (#YS-1755)
 Shock oil #450
 Piston #2 (Yok)
 Shock position 

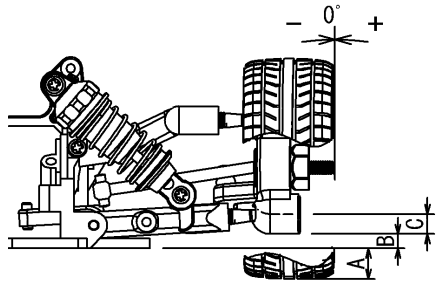

Width 190 mm
 Camber -2.0 °
 Ride height 4.5 mm
 Downstop 3.0 mm
 Bumpstop 0.0 mm
 Toe angle -2.0 °

Rear anti-roll bar None Kit mm
 Solid rear axle Gear diff Diff grease KIT
 190mm rear setup (short pillow balls & dogbones)
 200mm rear setup (long pillow balls & dogbones)

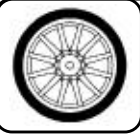

Front
 Tire - _____
 Insert - _____
 Wheel - _____

Rear
 Tire - _____
 Insert - _____
 Wheel - _____

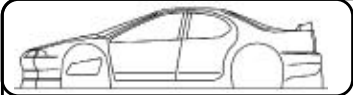

Body

Andy's Racing 200mm Stratus Body

Engine

Make - _____ Pipe - _____ Cooling head - _____
 Spec - _____ Manifold - _____ Head clearance - _____
 Plug - _____ Fuel - _____

Transmission

Single 2-Speed

1st gear (pinion / spur) 16 / 48
 2nd gear (pinion / spur) 19 / 45

Comments

Adjust shock collars to achieve correct ride height for front and rear.